

# Transport Conveyor

## Features

- T5 timing style conveyor belts for positive drive and precision positioning ability.
- Several belt materials available to service a wide range of pallet handling conditions.
- Utilizes all ball bearing supported rolling elements for long maintenance free operation.
- Certified for use in clean room environments.
- Antistatic materials available to suit operation in static sensitive areas or with static sensitive payloads.
- All maintenance operations including belt changes can be performed from the top eliminating the need to disassemble or remove ancillary equipment.
- Highly configurable.
- Bolt-up compatibility with other leading brands

## Specifications

- Speed Range – 3.5 to 70 m/min based on a 1750 motor RPM
- Payload Capacity – 250 Lbs. per strand.
- Minimum width – 140mm
- Minimum length – 174mm
- Belt Type – 25mm wide polyurethane core T5 timing belt with steel tension members
- Extruded aluminum construction with standard 10mm T-slots



learn more online: [glide-line.com](http://glide-line.com)

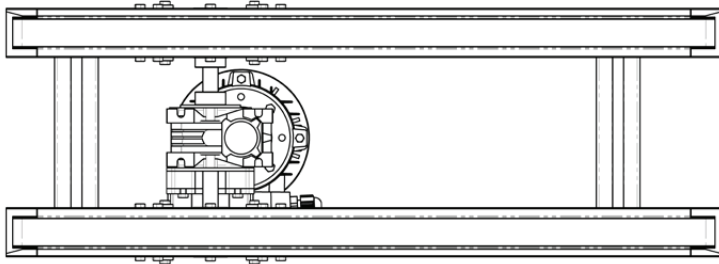
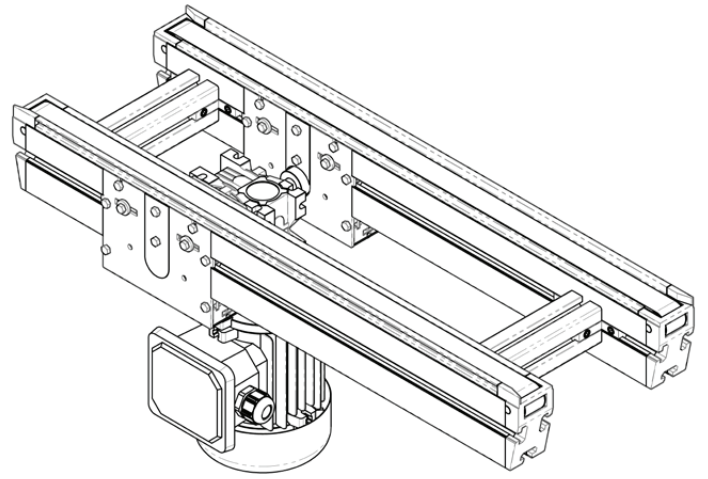
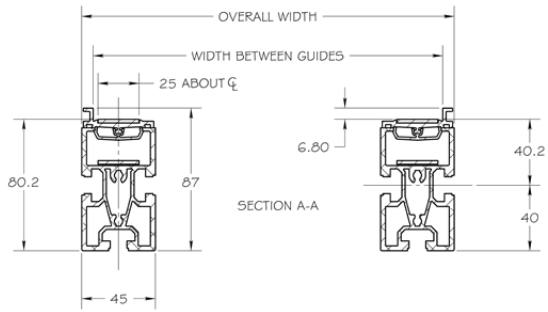

*GLIDE-LINE TRANSPORT CONVEYOR*

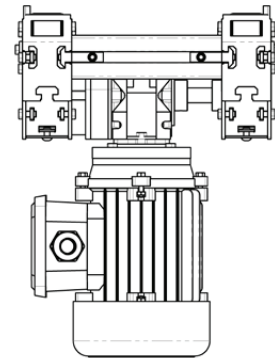
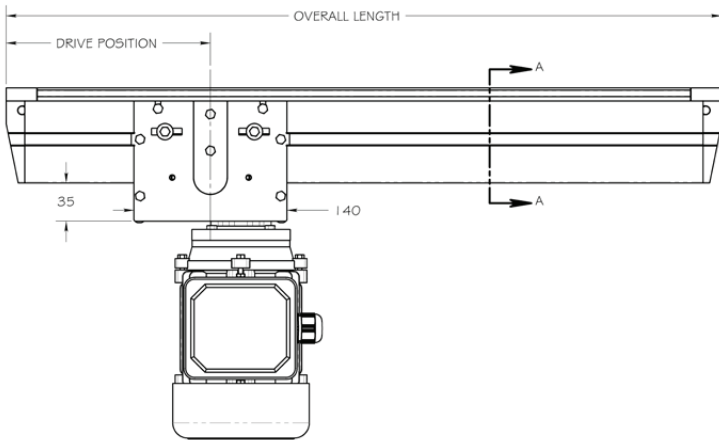

**Glide-Line™**  
255 Schoolhouse Road  
Souderton, Pennsylvania 18964

Phone: 215-721-1900  
Fax: 215-721-0633  
[www.glide-line.com](http://www.glide-line.com)